

SPIROL®

PIN INSTALLATION TECHNOLOGY

Model CR Semi-Automatic Pin Inserter

This robust, vertical pin insertion machine is ideally suited for moderate to high production for applications requiring up to 1,800 lbs. of installation force. A retractable pin orientation head, mounted on a shaft/linear bearing arrangement moves up and down for ease of loading and unloading of the components to be assembled. The insertion bushing is positioned close to the part for smooth, trouble free installation.

The orientation head shuttles the pin from the feeding position to the installation position, and also functions as a selector, preventing longer or shorter pins from being installed. A two position trap door allows for easy clear-out of the feed tube.

Design Features/Benefits:

- Precise:**
- Fine insertion depth adjustment
 - Doweled component location
 - Ground base plate to ensure perpendicularity between insertion quill and application
- Built to Last:**
- Cushioned cylinder return stroke
 - Hardened pin guide bushings and hard coated vibratory feeder bowl
- Versatile:**
- Can be easily configured to accommodate a variety of applications
- Efficient:**
- Automatically delivers pin to the installation site eliminating the need to touch the pin during entire assembly process
- Safe:**
- Guarded pinch points and anti-tie down, anti-repeat dual activation sensors (or optional foot switch with integrated finger protection unit)

Optional alignment fixtures available.

*Model CR
shown without guard*

*—
Guard is standard
with all machines*

*—
Shown with
optional fixture*

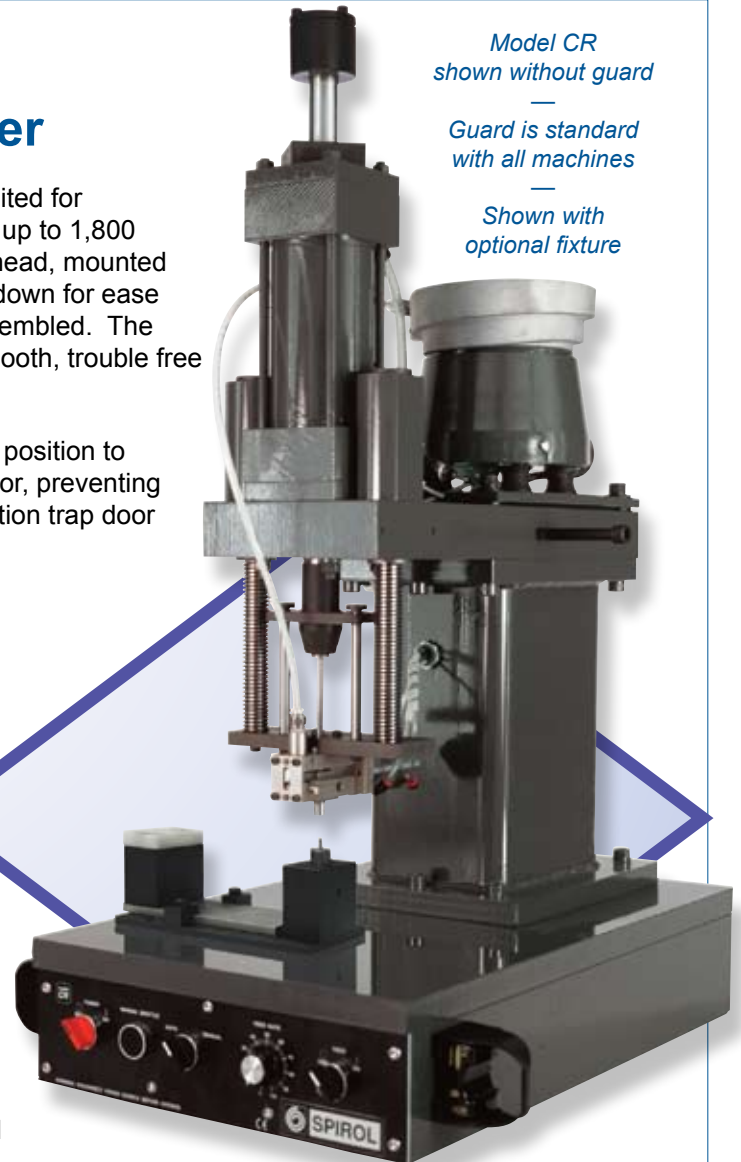

Dual and triple versions of the Model CR are readily available to suit your assembly objectives. Options such as rotary index tables, pin sensing, force monitoring, and drilling and pinning combinations can be added for enhanced productivity and heightened error-proofing.

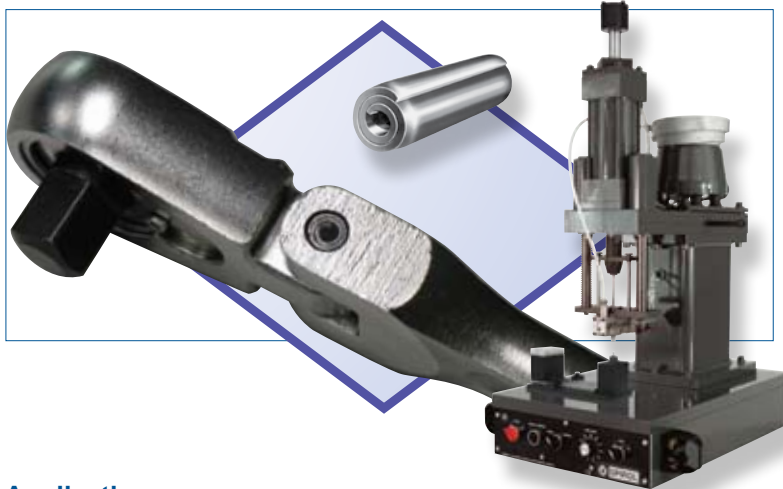
**Application:**

A major manufacturer of hand tools was experiencing difficulty installing an Ø8mm Solid Grooved Pin into a pivot joint of a Flexible Head Ratchet tool. The tolerance on the diameter of the hole resulted in the Grooved Pin either being too difficult to install, which required time-consuming secondary effort, or too easy to install, which resulted in a pin retention issue during use. The previous method of assembly consisted of manually placing the Grooved Pin in the hole, loading the assembly into a press, and activating the press ram. This assembly process took approximately 15 seconds, and the scrap rate approached 5%.

Solution:

SPIROL's Application Engineers recommended that the Solid Pin be replaced with an Ø8mm **Heavy Duty Coiled Pin**. The Coiled Pin's design enables it to absorb the wide hole tolerance without any adverse effects on performance. In addition, the unique characteristics of the Coiled Pin provides enough strength to withstand the forces generated during use, and the flexibility to absorb repetitive loading. The Coiled Pins are installed with **SPIROL**'s standard **Model CR Automatic Pin Inserter**. The operator simply loads the assembly into a fixture, and then touches the dual optical actuation switches. Once the machine is activated, the insertion head advances, installs the pin, retracts and resets for the next cycle. This process is completed in only 5 seconds.

SPIROL provided the complete assembly solution. The reduction in assembly time and scrap paid for the machine in eight months.

Challenge Us!

SPIROL Application Engineers will review your application needs and work with your design team to recommend the best solution. One way to start the process is to select Installation Systems in our Optimal Application Engineering portal at www.SPIROL.com.

U.S.A. Spirol International Corporation
30 Rock Avenue
Danielson, Connecticut 06239
Tel. 860.774.8571 Fax 860.774.2048

Spirol West Inc.
1950 Compton Avenue, Unit 111
Corona, California 92881-6471
Tel. 951.273.5900 Fax 951.273.5907

**Spirol International Corporation
Shim Division**
321 Remington Road
Stow, Ohio 44224
Tel. 330.920.3655 Fax 330.920.3659

Spirol Distribution
30 Rock Avenue
Danielson, Connecticut 06239
Tel. 800.321.4679 Fax 860.774.0487
(For Distributor Customers)

Canada Spirol Industries, Ltd.
3103 St. Etienne Boulevard
Windsor, Ontario
Canada N8W 5B1
Tel. 519.974.3334 Fax 519.974.6550

Mexico Spirol México, S.A. de C.V.
Carretera a Laredo KM 16.5 Interior E
Col. Moisés Saenz
Apodaca, N.L. 66613 México
ó Apdo. Postal 151 de Apodaca, N.L.
Tel. (81) 8385 4390 Fax (81) 8385 4391

Europe Spirol Industries, Ltd.
Princewood Road
Corby, Northants
England NN17 4ET
Tel. 44 (0) 1536 444800
Fax 44 (0) 1536 203415
(For Distributor Customers)
Tel. 44 (0) 8003 890034

Spirol SAS
Rue Henri Rol Tanguy
Z.A. Les Naux
51450 Bétheny
France
Tel. 33 (0)3 26 36 31 42
Fax 33 (0)3 26 09 19 76

Spirol GmbH
Briener Strasse 9
80333 Munich
Germany
Tel. 49 (0) 931 454 670 74
Fax. 49 (0) 931 454 670 75

**Asia Pacific Spirol International Engineered
Fastener Trading Co. Ltd.**
No. 11 Xi Ya Rd. North
Section A, 1F, Building 14
Wai Gao Qiao Free Trade Zone
Shanghai, China 200131
Tel. (8621) 5046 1451/1452
Fax (8621) 5046 1540

e-mail: info@spirol.com

SPIROL.com

Request a free **SPIROL Automation CD-ROM** that demonstrates the Pin Inserters in operation, presents their versatility, and lists cost-effective options available for your application.